

Assembly Instructions

Spartan 4 Short Single Sided

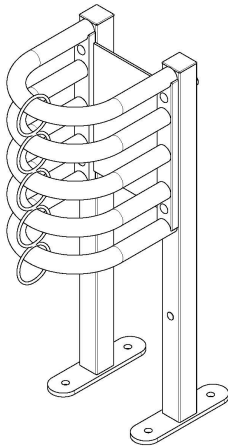

Spartan 7 Short Single Sided

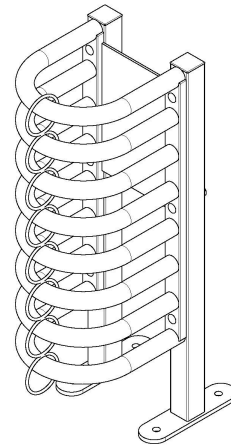

Spartan 7 Tall Single Sided

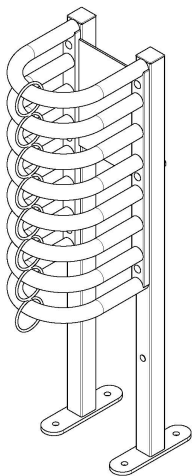

Spartan 10 Tall Single Sided

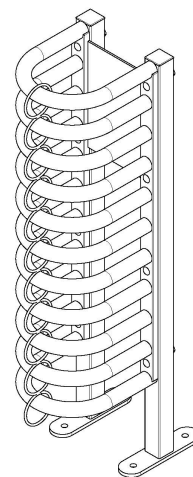

Assembly Parts and Instructions

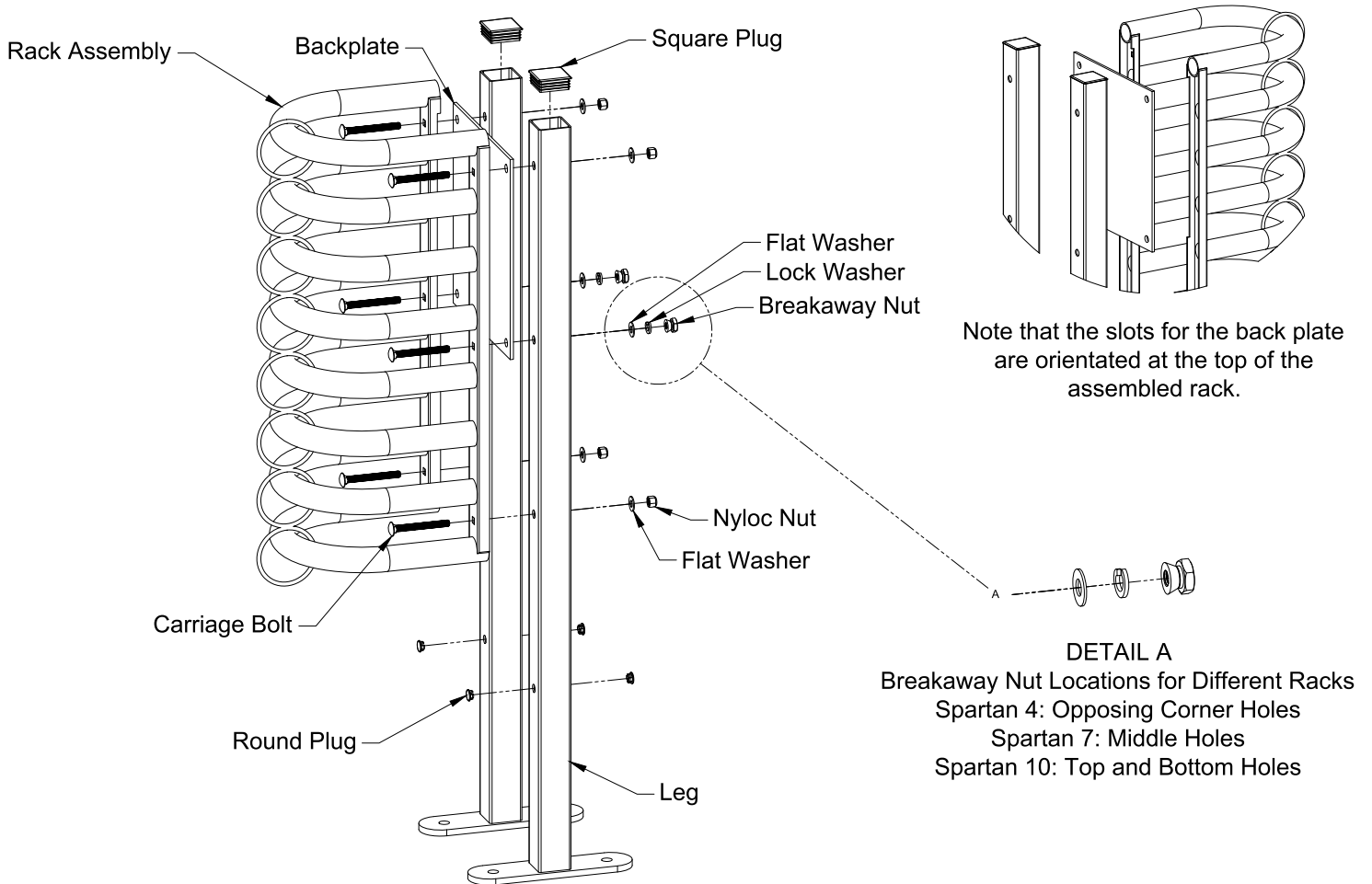

Attach rack assembly and backplate to legs using provided hardware as shown. Install applicable plugs.

Hardware:

Mounting hardware is designed for specific mounting surface materials. Only use mounting hardware that was designed for your specific mounting surface.

This skateboard security rack is designed to mount to a solid and level concrete or masonry brick surface with a minimum thickness of 4 inches. The mounting surface must also contain adequate structural integrity to be able to withstand the mechanical forces from the daily use of this product.

Each skateboard security rack has several mounting holes (depending on the model you have purchased) for securing the rack to the mounting surface selected. It is important that all mounting holes are used when securing the unit to the mounting surface. In addition, select mounting hardware that has an adequate diameter (slightly smaller than the mounting holes provided), and length to ensure the skateboard rack is sufficiently attached to the mounting surface.

Below are a couple examples of masonry type anchors that can be used to mount skateboard security racks to a solid and level concrete or masonry brick wall/floor surface (image are from the McMaster-Carr). These anchors can be found at most local hardware and home improvement type stores.

Removable-Bolt Anchors for
Concrete, Solid Block, and Brick

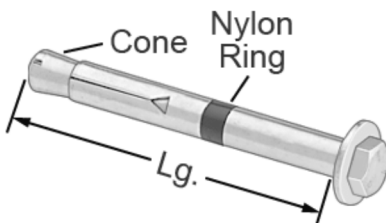

Heavy Duty Pin-Drive Anchors for

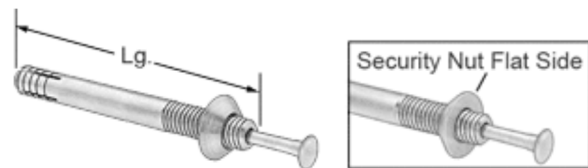

**For additional information about mounting hardware, or where to
obtain hardware, please call 855-853-3454.**

Installation:

1. This skateboard security rack is designed to be mounted to a flat concrete or masonry brick wall surface (mounting surface). Mounting surfaces vary greatly in their composition, construction and structural integrity. It is up to the customer to determine an appropriate mounting surface, and select the correct hardware for the mounting surface used. The manufacture recommends routine and regular inspections of the mounting surface and mounting hardware to ensure the safe use of this product.
2. The skateboard security rack should be mounted at a height so that the top security slot of the rack is within reach of all potential users of the rack. Note: If the rack is being mounted in a public space it must be mounted so that it meets the Americans with Disabilities Act of 1990. (consult the ADA Accessibility Guidelines for Buildings and Facilities provided).
3. The skateboard security rack should be mounted so that its use is not obstructed by other objects in the area; including doors, windows, landscaping, and other items secured or fastened to the same mounting surface. The skateboard security rack should also not be placed close to the edge or corner of a wall, which may allow the skateboards to protrude out from the corner of the mounting surface creating a hazard. Refer to the Free Space Requirements for additional information.
4. Inspect the skateboard security rack several times per year to ensure that it is safe and in good working order. Check that assembly hardware is tight, the rings are in good working order, and that the rack mounting points are secure. Replace any parts that appear to be worn, damaged or unsafe. Replacement parts are available through Loch Unlimited, Inc. Call toll free 855-853-3454 or e-mail us at info@boardloch.com.

Free space requirement:

The diagram below represents the minimum unobstructed free space that is needed around the unit to ensure safe and proper use of the skateboard security rack.

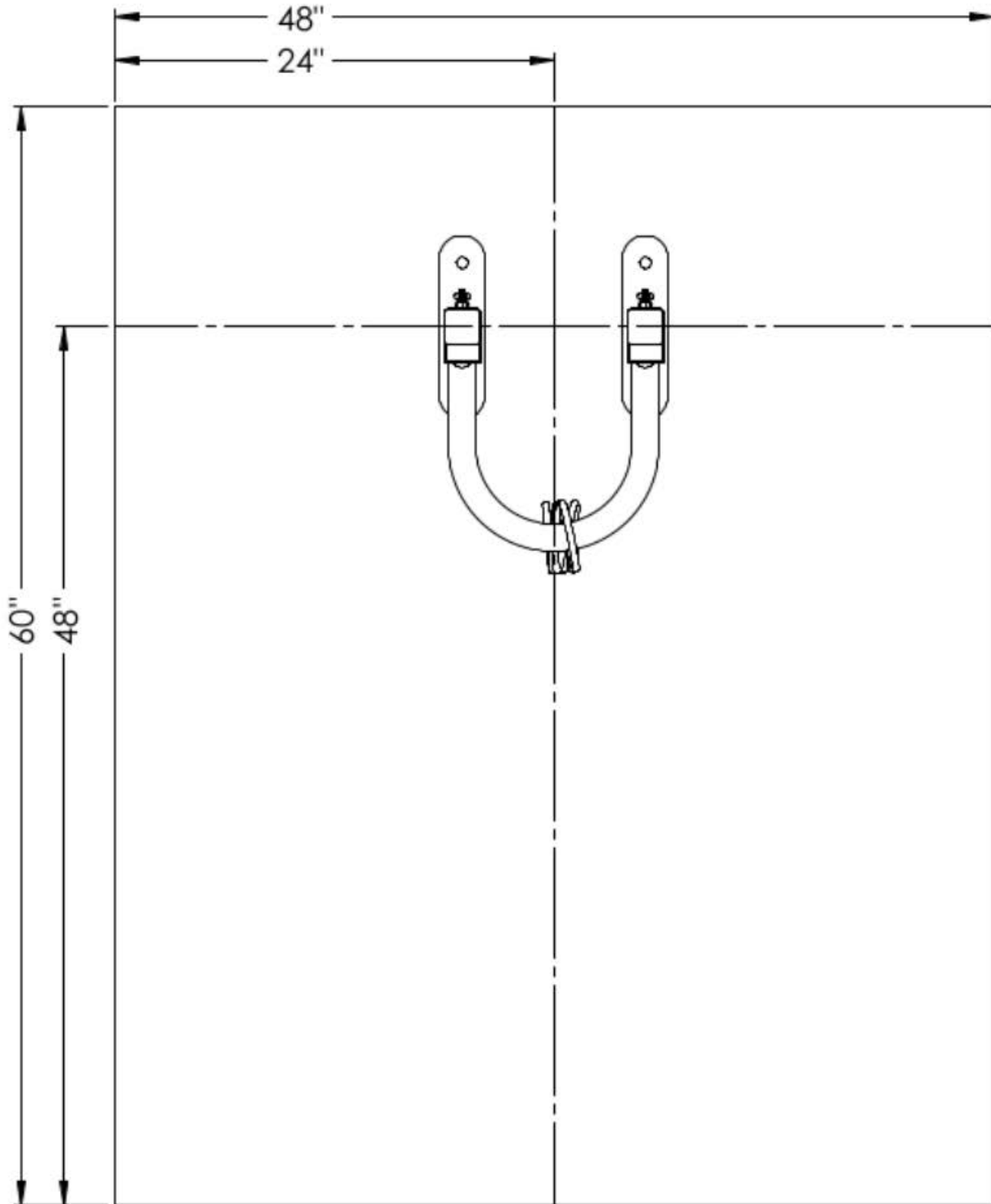

ADA Accessibility Guidelines for Buildings and Facilities (ADAAG)

****NOTE: The following information is provided for reference ONLY. It is the responsibility of the person(s) or party that is providing, installing and/or using Boardloch or Dek-Dok brand products to adhere to any and all rules and regulations that would effect the placement and use of these products. Loch Unlimited, Inc. is not responsible for the improper placement of Boardloch or Dek-Dok brand products, or any injuries, judgments, or fines that may result from the intentional or unintentional placement of these products.***

4.4 Protruding Objects.

4.4.1* General. Objects projecting from walls (for example, telephones) with their leading edges between 27 in and 80 in (685 mm and 2030 mm) above the finished floor shall protrude no more than 4 in (100 mm) into walks, halls, corridors, passageways, or aisles (see [Fig. 8\(a\)](#)). Objects mounted with their leading edges at or below 27 in (685 mm) above the finished floor may protrude any amount (see [Fig. 8\(a\)](#) and [\(b\)](#)). Free-standing objects mounted on posts or pylons may overhang 12 in (305 mm) maximum from 27 in to 80 in (685 mm to 2030 mm) above the ground or finished floor (see [Fig. 8\(c\)](#) and [\(d\)](#)). Protruding objects shall not reduce the clear width of an accessible route or maneuvering space (see [Fig. 8\(e\)](#)). [Appendix Note](#)

4.4 Appendix Note.

A4.4.1 General. Service animals are trained to recognize and avoid hazards. However, most people with severe impairments of vision use the long cane as an aid to mobility. The two principal cane techniques are the touch technique, where the cane arcs from side to side and touches points outside both shoulders; and the diagonal technique, where the cane is held in a stationary position diagonally across the body with the cane tip touching or just above the ground at a point outside one shoulder and the handle or grip extending to a point outside the other shoulder. The touch technique is used primarily in uncontrolled areas, while the diagonal technique is used primarily in certain limited, controlled, and familiar environments. Cane users are often trained to use both techniques.

Potential hazardous objects are noticed only if they fall within the detection range of canes (see [Fig. A4](#)). Visually impaired people walking toward an object can detect an overhang if its lowest surface is not higher than 27 in (685 mm). When walking alongside protruding objects, they cannot detect overhangs. Since proper cane and service animal techniques keep people away from the edge of a path or from walls, a slight overhang of no more than 4 in (100 mm) is not hazardous.

Additional Information.

Contact the United States Access Board for more information and to ensure that your application meets the accessibility guidelines for buildings and facilities as set forth by the Americans with Disabilities Act of 1990.

United States Access Board
1331 F Street, NW, Suite 1000
Washington, DC 20004-1111

Phone (voice): (202) 272-0080 toll free: (800) 872-2253

Phone (TTY): (202) 272-0082 toll free: (800) 993-2822

Fax: (202) 272-0081

E-mail: info@access-board.gov

Source: <http://www.access-board.gov/adaag/html/adaag.htm#4.4>

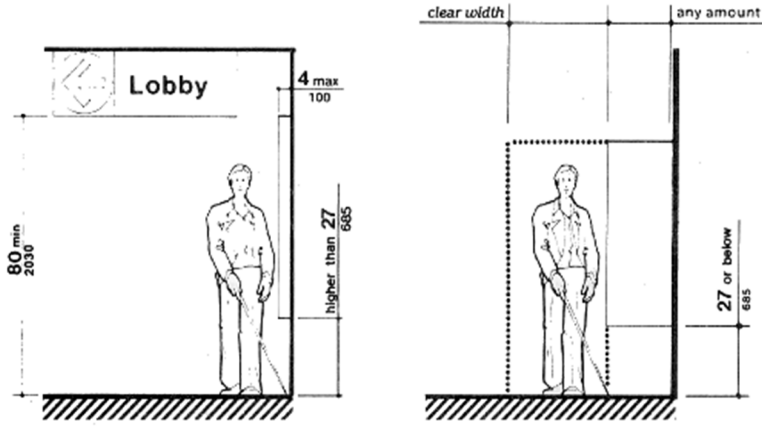

Figure 8a
Protruding Objects
Walking Parallel to a Wall

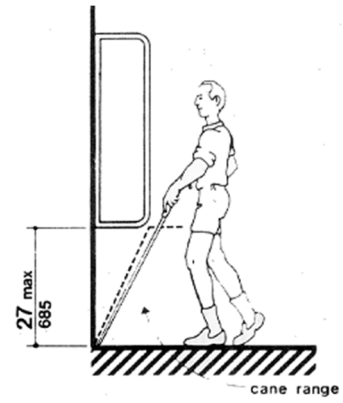

Figure 8b
Protruding Objects
Walking Perpendicular to a Wall

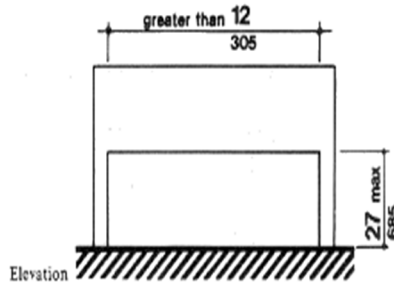
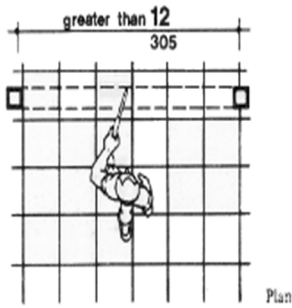

Figure 8c
Protruding Objects
Free-Standing Overhanging Objects

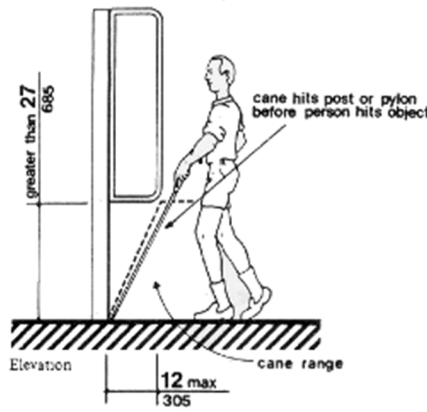
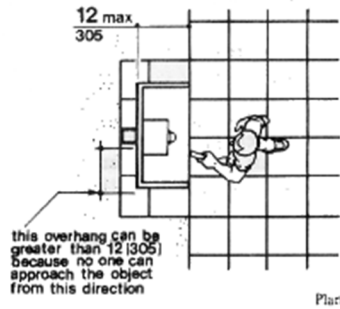

Figure 8d
Protruding Objects
Objects Mounted on Posts or Pylons

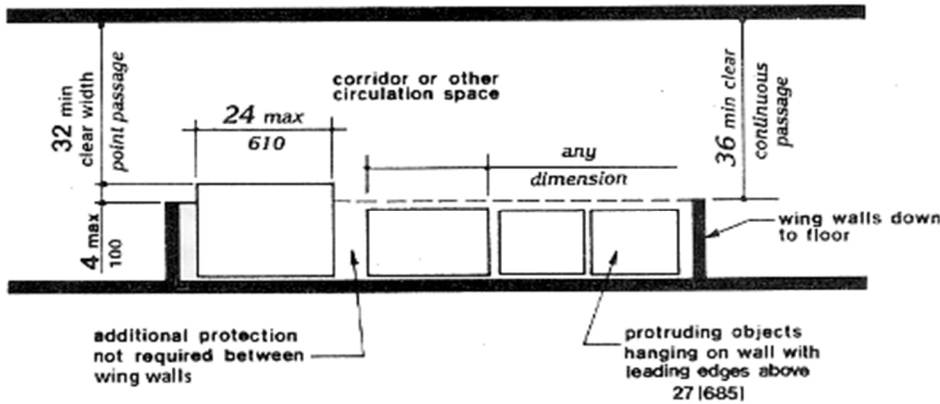

Figure 8e
Protruding Objects
Example of Protection
around Wall-Mounted Ob-
jects and Measurements
of Clear Widths

This document is provided by Loch Unlimited, Inc., and it is intended to be used for reference purposes ONLY. Please refer to additional Federal, State, and/or local regulations that could influence the placement of products.

TERMS AND CONDITIONS
for Boardloch® brand security products

An order placed with Loch Unlimited, Inc.; (referred to as "LUI" from this point forth) manufacturer of the Boardloch® brand products, constitutes an offer by you, and by placing that order the purchaser agrees to the following terms and conditions of sale below.

Payment Options

LUI offers three payment options to the purchaser:

- 1) The purchaser may pay using a credit card. A representative from LUI will contact the customer to obtain their credit card information. Once the purchase amount has posted to the bank account of LUI, LUI will process the order. Credit cards must be used to prepay for all special orders. In addition, all approved dealers must prepay for their first order. Lastly, purchasers that are not governmental agencies, or are not ordering through a school district's formal purchasing process must use a credit card to prepay for their order.
- 2) The purchaser may pay in advance by business, cashier or personal check; provided that shipment will be delayed until the check has cleared, after which LUI will be obligated to fulfill the order.
- 3) With prior approval LUI will accept a Net-30 purchase order payment from educational and/or governmental agencies that produce a purchase order. Outstanding balances more than thirty (30) days past due will be assessed a 10% service charge plus an additional 5% for every fifteen (15) days there after until payment in full is received.

LUI does not collect sales tax as it is an Oregon based Corporation. If applicable, the purchaser is responsible for paying sales tax directly to their State organization at their specified state sales tax rate. Prices for products and shipping charges are subject to change without notice at any time prior to an order being placed.

Limited Warranty

Boardloch® brand products come with a twelve-year limited warranty.

1) What is covered by this limited warranty?

This limited warranty covers defects in materials and workmanship of Boardloch® brand products manufactured by LUI on a prorated basis for a period of twelve years from the invoice date. *Finishes including galvanizing, zinc plating and powder coating are exclusive of this twelve-year limited warranty and have a one-year limited warranty.* LUI will repair or replace, at their sole discretion, any defective Boardloch® brand product upon payment of a service charge in the following amounts:

For products returned under this limited warranty during the first four years from the date of the original invoice a payment of 75% of the original invoice price, plus shipping and handling.

For products returned under this limited warranty during the fifth through eight years from the date of the original invoice a payment of 50% of the original invoice price, plus shipping and handling.

For products returned under this limited warranty during the ninth through twelfth years from the date of the original invoice a payment of 25% of the original invoice price, plus shipping and handling.

Obtaining service under this warranty does not operate to extend the warranty period. If LUI repairs or replaces a Boardloch® product under this warranty LUI will thereafter own all parts removed from repaired products or the replaced product.

2) What do I do if I need warranty service?

Please e-mail, call, or write to LUI Customer Service to obtain a Warranty Authorization (WA) number. No Boardloch® products will be accepted without a WA number. The applicable warranty period above shall be determined by the invoice date and the date the WA number is issued.

You must return the product to us within ten days from the date that LUI issues the WA number, prepay shipping charges, and either insure the shipment or accept the risk if the product is lost or damaged in shipment. LUI may also require you to provide a written description of the defect(s), and photos of the defective area as a condition of performing the warranty.

This limited warranty may be transferred if the current owner transfers ownership and records the transfer with LUI. You may record your transfer by e-mailing, calling, or writing to the LUI customer service.

3) Who do I contact for warranty related issues?

Contact LUI at:

Loch Unlimited, Inc.
64682 Cook Ave., Suite 35
Bend, OR 97703
1-855-853-3454 or Email address: info@boardloch.com

4) What is not covered by this limited warranty?

Boardloch® brand products that have been damaged, vandalized, altered, modified, exposed to corrosive materials, and/or assembled, installed, used not in accordance with product specifications are not covered.

Hardware failures, the movement or settling of mounting surfaces, the structural integrity of mounting surfaces or from unforeseen acts of God.

This warranty does not cover costs associated with the installation or removal of any Boardloch® products for return.

This warranty does not cover services not authorized by LUI.

This warranty does not cover damage caused by using accessories, parts, or components not supplied by LUI.

This warranty does not cover products for which LUI have not received payment.

If LUI determines that the problem is not covered under this warranty, LUI will notify you and inform you of alternatives that are available to you on a fee basis.

Return Policy

Please e-mail or call LUI Customer Service to obtain a Return Authorization (RA) number within thirty (30) days of the date on the invoice for a credit or a refund of the price paid, less shipping and handling, provided that the product has not been installed, altered or otherwise damaged and is returned in its original packaging.

You must obtain an RA number in order to return the product for credit, and you must ship the products to LUI within ten (10) days of the date LUI issues the RA number. No returned Boardloch® products will be accepted by LUI without an RA number. You must also agree to prepay return shipping charges, and either insure the shipment or accept the risk of loss or damage during return shipment.

The returned product must be in as-new condition and returned with any other items that were included in the original shipment. Items that have been installed, altered or otherwise damaged are subject to a reduction or denial of the refund amount. All returns are subject to a restocking fee of fifteen percent (15%) of the invoice price that will be deducted from any refund or credit.

1) Who do I contact for product return related issues?

Contact LUI at:

Loch Unlimited, Inc.
64682 Cook Ave., Suite 35
Bend, OR 97703
1-855-853-3454
Email address: info@boardloch.com

Shipping

Products are shipped F.O.B. Destination, freight prepaid and charged back, therefore a shipping and handling charge will be added to the invoice price. Most shipments (unless previously agreed upon in writing) will utilize UPS ground shipping as a carrier. The purchaser is responsible for making arrangements to receive the product and inspect the shipment upon arrival to ensure the proper order was received and that the material has not been damaged during the shipping process.

If the purchaser determines that the order is incorrect, the merchandise has been damaged, and/or if the purchaser refuses delivery of the order altogether, the purchaser must notify LUI within three (3) business days from the date the order is delivered. Otherwise the order will be deemed to have been properly fulfilled by LUI.

Miscellaneous

The purchaser agrees that it is the responsibility of the purchaser to evaluate a mounting surface to determine whether it is suitable for mounting a Boardloch® product. The purchaser therefore agrees to accept sole risk and responsibility for the proper selection of a mounting surface and for any damages to the mounting surface resulting from improper selection.

This warranty gives you specific legal rights, and you may also have other rights which vary from state to state. All express and implied warranties for the product, including, but not limited to, any implied warranties of merchantability or for fitness for a particular purpose are limited in time to the term of the limited warranty period. No warranties, whether express or implied, will apply after the limited warranty period has expired. Some states do not allow limitations on how long an implied warranty lasts, so this limitation may not apply to you.

LUI does not accept liability for consequential or incidental damages, including but not limited to any liability for third-party claims against you for damages or for products not being available for use. In any case our liability is limited to the amount paid for the product that is the subject of a claim. Some states do not allow the exclusion or limitation of incidental or consequential damages, so the above limitation or exclusion may not apply to you.

The above Terms and Conditions shall be treated as though it were executed and performed in Bend, Oregon and shall be governed by and construed in accordance with the laws of the United States of America and of the state of Oregon (without regard to conflict of law principles). The language in the above shall be interpreted as to its fair meaning and not strictly for or against any party.

Should any part of the above terms and conditions be held invalid or unenforceable, that portion shall be construed consistent with applicable law as nearly as possible to reflect the original intentions of the parties and the remaining portions shall remain in full force and effect. To the extent that anything in or associated with the boardloch.com internet web site is in conflict or inconsistent with the above, the above shall take precedence.

Boardloch® is a registered trademark of LUI and all rights are reserved.